

Project Name: _____

Date: _____ Note: _____

LED Architectural Recessed Luminaire PL5005



Application: Offices, Schools, Showrooms, Airports, Retail and Healthcare Facilities...



Optional Accessories



Emergency Back-Up



Sensor (ANT-7D)

Features

- UL&DLC Listed
- Offers 5 selectable wattages and 5 color temperature options
- Backlit design for uniform, glare-free light distribution
- High luminous efficiency of up to 140 lm/W
- Optional emergency backup kit available
- Suitable for recessed, surface-mounted, or suspended installations

Specifications

Model NO	PL5005	PL5005
Power	40/30/25/20/15W	72/50/40/30/20W
Size	2'x2'	2'x4'
Input Voltage	120-277 VAC	
Dimming	0-10V Dimmable	
Lumen	4890 LM	10087 LM
Protection Rating	IP20 (For Indoor Use Only)	
Power Factor	>0.9	
Beam Angle	110°	
CCT	6500-5000-4000-3500-3000K Selectable	
CRI	>80	
DLC #	S-39BTZ1	S-26G3GL
Lifespan	Lumen Maintenance over 70% @ 50,000+ Hours	
Working Temperature	-13 °F~ +113°F/-25°C~ +45°C	
PC/Pack	2	

Project Name: _____
Date: _____ Note: _____

LED Architectural Recessed Luminaire PL5005

Ordering Code Definition

Code	Product	Size	H	TW	CCT	Suffix
PL5005	PB: LED Backlit Panel	2X2P: 2'x2'	120-277V	Tunable Wattage	30K/35K/40K/50K/65K	(XX)
		2X4P: 2'x4'				

Product Dimensions

2'X2' Front View

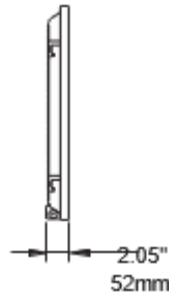
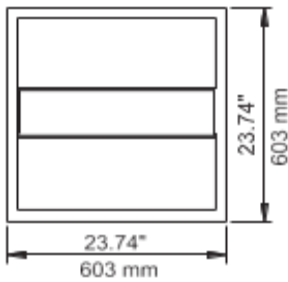

2'X4' Front View



Package Information

Model NO	PL5005 -2X2P-XX-TWCCT(XX)	PL5005 -2X4P-XX-TWCCT(XX)
Size	2'x2'	2'x4'
Qty/Pack	2 PCS	
Package Size	655X125X665mm 25.79"x4.92"x26.18"	1265X125X665mm 49.80"x4.92"x26.18"
Package Weight	4.3kg / 9.48LBS	9.66kg / 21.29LBS
Package CBM	0.05	0.11

LED Architectural Recessed Luminaire PL5005

Photometric Report

2X4 50W

LED BACKLIT PANEL

LUMINOUS INTENSITY DISTRIBUTION DIAGRAM

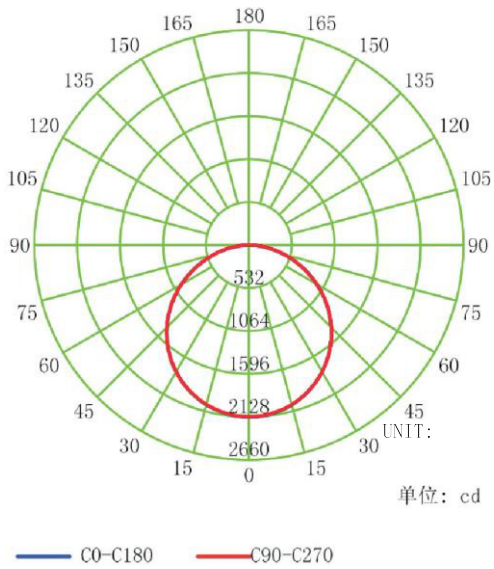

VERTICAL EQUILUMINOUS CURVE

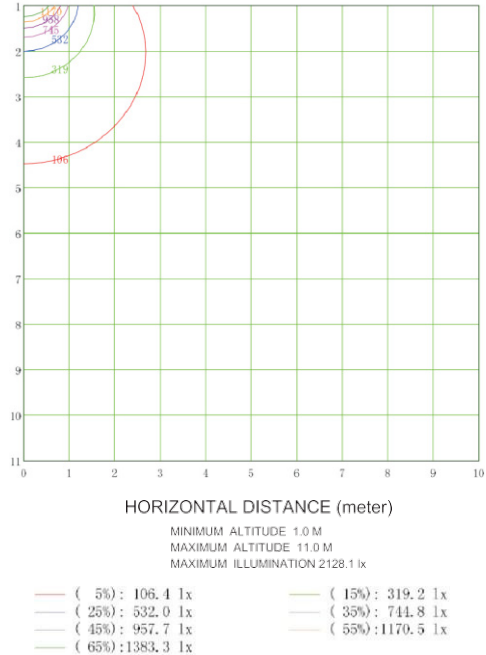

Safety Installation

Read Before Installation:

Always follow basic safety precautions when installing. These include:

- Carefully read all instructions prior to installation.
- Professional installation and maintenance are required for this LED panel.
- Use only a dedicated external LED driver to power the LED panel.
- Disconnect the power supply before installation or maintenance.
- Ensure all wires are properly connected before powering on the device.
- Provide sufficient space for heat dissipation.
- Never cover the luminaire with heat insulation mats or slim layer materials.
- IP40 rating is for indoor use only (not suitable for damp locations); IP54 rating is for indoor damp locations.
- Operating temperature: -10°C to +45°C. Avoid direct sunlight.
- Store in cool, dry conditions.

WARNING:

- Switch off before installation.
- Switch on only after complete installation and examination of the circuit.



Turn off Power Supply

CAUTION:

Make sure that the mounting surface or structural member used for installation can support the weight of LED Panel.

LED Architectural Recessed Luminaire PL5005

Wiring Guide

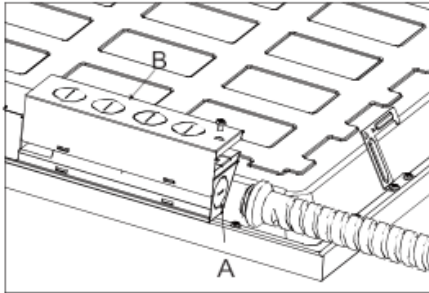

(1) Remove the knock-down hole on box by screwdriver (Part A), Remove screw and take out the driver cover (Part B)

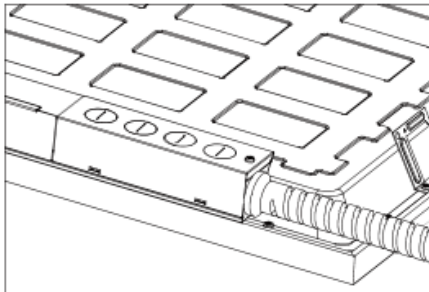

(3) Cover the driver box and tighten it with a screwdriver, finish connection.

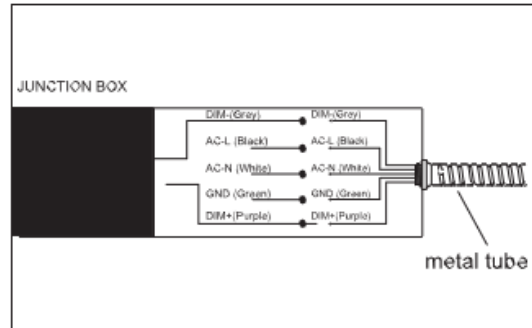

(2) Connect the wire as the picture showing.
※ This knock-out at side surface is not permitted for branch circuit entry into the luminaire.

For the product with Slide Switch of CCT or power selection, please select the CCT or power needed before installation. (Ignore these steps if without the function)

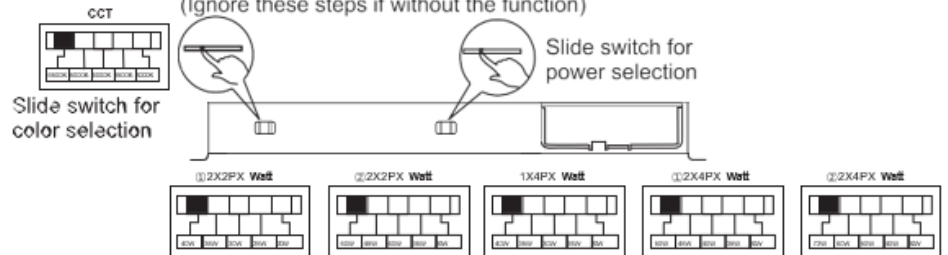

Installation Instruction

Lamp inspection before installation:
please adjust the lamp with below steps before installation:
1. Press the opposite angles at the same time;
2. Press another two opposite angles at the same time, make sure the four angles are flat, then start the installation.
Take out the lamp from the box and put it in a flat table, if the lamp upwarps,

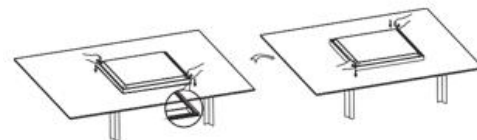

Recessed

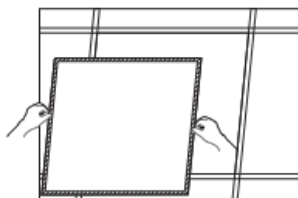

Remove the ceiling plaster slab.

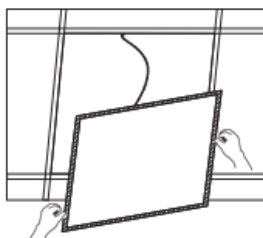

Fix the panel light into plaster ceiling.



② Feed the main AC wire in driver terminal block respectively, connect the panel light and driver.

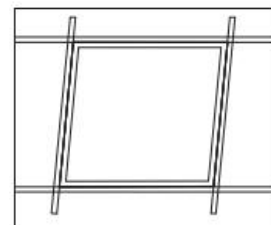

Make sure the led panel light is firmly fixed, turn on the power.

LED Architectural Recessed Luminaire PL5005

Suspended

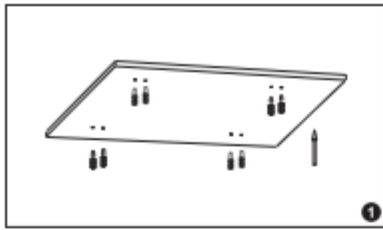

① place on the ceiling.
Fix the anchor into target

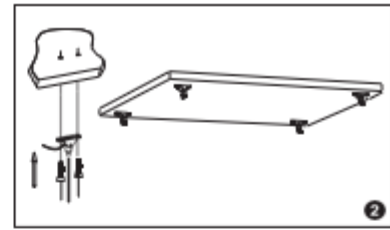

② on the ceiling with plastic
anchor.
Fix the installation mount

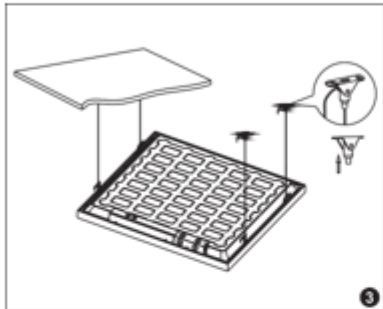

③ suspended installation kits, adjust
the length of steel wires.
Hang the panel to ceiling with

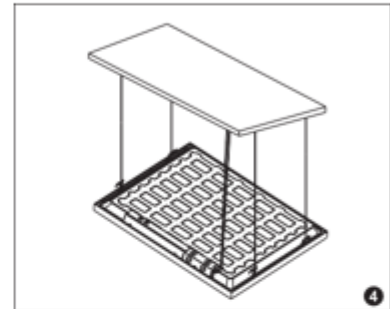

④ driver terminal block respectively,
turn on the power.
Feed the main AC wire in

Surface mounted

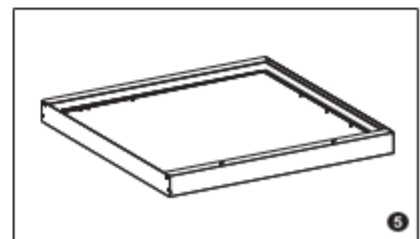
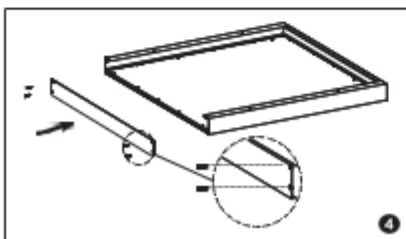
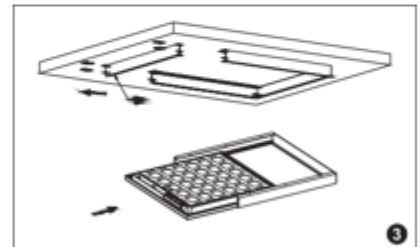
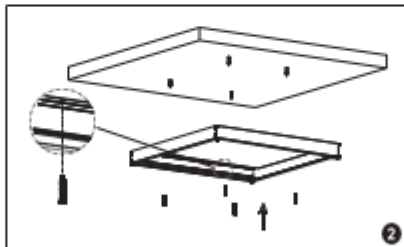
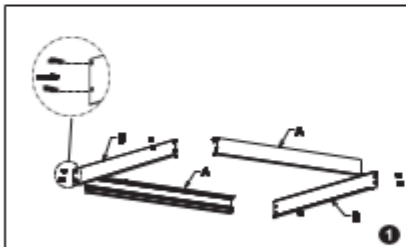

Assemble the surface mounted frame and fix by screws.
knock the plastic anchor into ceiling, fix the surface mounted frame on the ceiling by screws.
Unscrew the side frame then take out, connect the panel light to power supply, insert the panel light into the frame.
Fix the side frame back by screw.
Make sure the frame and panel light are firmly fixed, turn on the power.

Recessed Mounting(Clips)

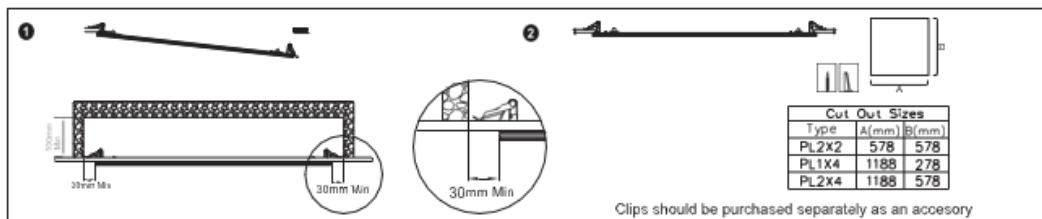

WARNING:
Input wire diameter $\geq 0.75\text{mm}^2$;
Product modification and improper installation are not valid for warranty!

Project Name: _____
Date: _____ Note: _____

LED Architectural Recessed Luminaire PL5005

Sensor Installation Guide

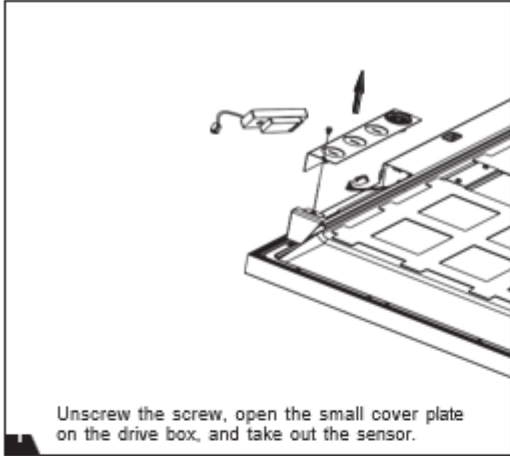

Unscrew the screw, open the small cover plate on the drive box, and take out the sensor.

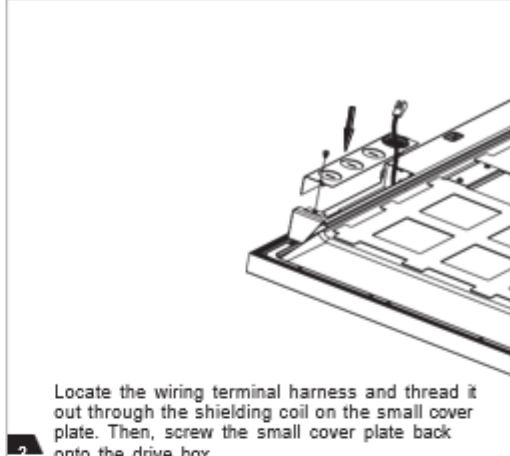

Locate the wiring terminal harness and thread it out through the shielding coil on the small cover plate. Then, screw the small cover plate back onto the drive box.

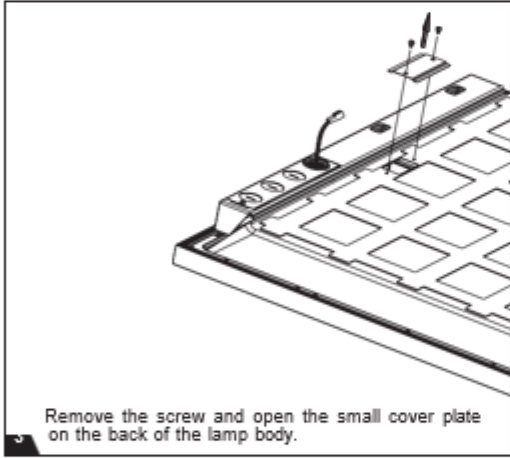

Remove the screw and open the small cover plate on the back of the lamp body.

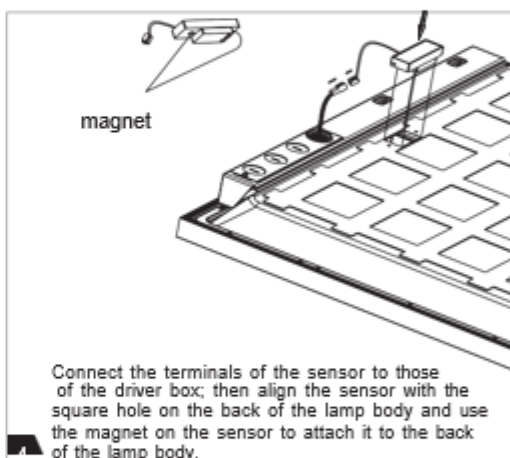

Connect the terminals of the sensor to those of the driver box; then align the sensor with the square hole on the back of the lamp body and use the magnet on the sensor to attach it to the back of the lamp body.

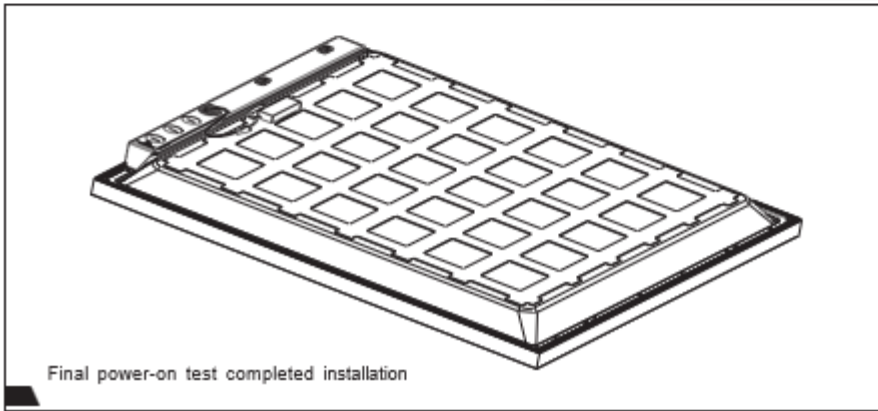

WIRING DIAGRAMS

Wiring with dimming ballast or LED driver.

